

DICK SMITH'S
EASY GUIDE TO
UNDERSTANDING
YOUR COMPUTER

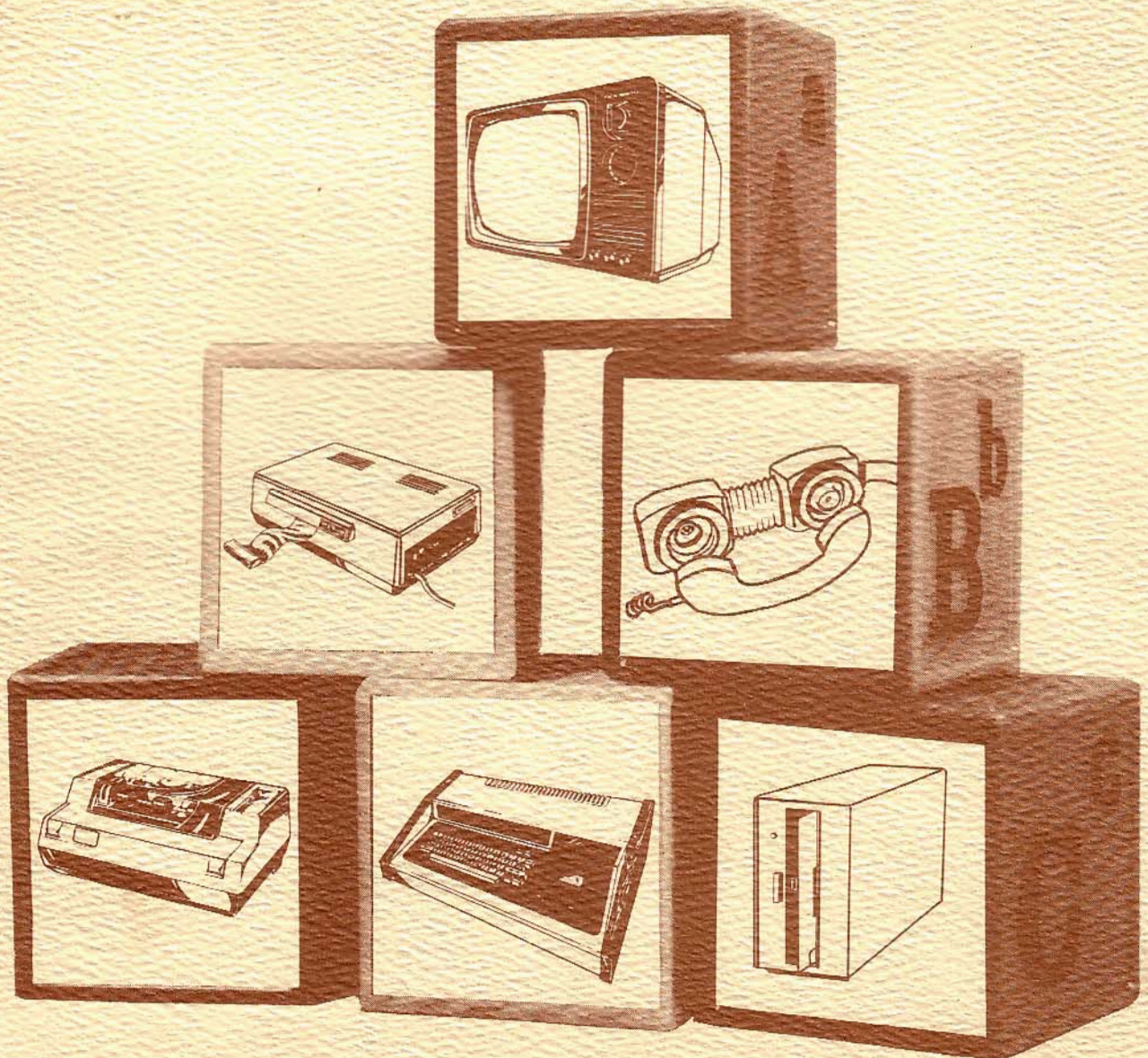

HOW YOUR DICK SMITH BUSINESS COMPUTER WORKS - BASIC CONCEPTS

What is a computer?

A computer is a machine that is capable of performing many functions. Some of these are:-

- It can act as a filing clerk (with its own cabinet) by storing information on files and retrieving it from files on request.
- It can keep accounts, records of your stock and personnel and payroll details
- It can type out copies of its files or be used as a word processor
- It can manipulate the information in its files (for example - adding sets of figures and performing other calculations, changing the spelling of a word, changing the format of text to be typed out and so on)

It can only carry out these functions if it is instructed to do so by programs. These are sets of instructions for the computer and are called SOFTWARE. A computer is very much like a pianola and programs operate very much like a pianola roll. The pianola is capable of playing a huge variety of tunes but can't do so unless you put in the pianola roll to "tell" it what to play. Computer software performs the same function for the computer. It is put in the computer and tells it what to do with the data and information you then feed in. However, unlike the pianola roll, the instructions stay in the computer so that the computer can move back and forward along the program. It doesn't have to "read" the instructions from the start to the end, like a pianola roll.

In order to do these things the computer has to be able to carry out a series of basic operations:-

- It has to be able to receive input from you. That is, there must be a facility that lets you give it the information to store, manipulate or print.
- It has to be able to store the information or file it away. It also has to be able to store the program. That is, it needs a memory.
- It has to be able to manipulate the information, allocate it to the right file and so on. In other words, it needs "intelligence" to process the information as you tell it to.

- Finally, it has to be able to tell you the results of its work. It must be able to produce output.

The computer's components

There are various pieces of equipment that carry out the operations mentioned above. The basic parts are as follows:-

1. THE INPUT DEVICES

These are pieces of equipment that allow you to give information or instructions to the computer. The most common input devices are the keyboard, cassette recorders and disk drives (you use these to input data and programs already prepared and recorded on tape or disk). The computer "reads" the information and uses it or stores it.

2. THE CENTRAL PROCESSING UNIT (CPU)

This is the computer's "brain". It is the part of the computer which performs arithmetic functions and logical operations such as sorting and comparing, when instructed by the program.

3. THE MEMORY

This is the part of the computer that stores data or programs and retrieves them when necessary. The memory is made up of a series of silicon chips (integrated circuits). It is possible to expand the computer's usable memory up to 48K by plugging in more chips. You can also effectively expand the usable memory by storing information on disks or tapes.

4. THE OUTPUT DEVICES

These are the devices that the computer uses to tell you the results of its work (be it filing or manipulating data). The most basic commonly used output devices are video screens (to "echo" what you are entering on the keyboard or to show the results of the computer's work) and printers (to type the output on paper). The computer can also "write" or output its results using the same disk drives or cassette recorders you use for input.

These components all work together to perform the functions of a computer. If you used the system to add information to files, for example, it would work as follows -

You use a disk drive (INPUT DEVICE) to enter a program (pre-recorded on a disk) into the computer.

The program tells the computer where to file the data you are going to enter.

You use the keyboard (another INPUT DEVICE) to give the computer the data. The computer lets you see the data on the video screen as you enter it.

It then stores the data in the files (stored in its MEMORY) according to the instructions it received in the program. To do this it uses the CPU.

You tell it (using the keyboard again) to print out the updated files and it does so using the printer (an OUTPUT DEVICE).

There are 2 ways to get a program for your computer. You can buy pre-prepared programs on disks or tapes or you can write your own (or hire a consultant to write them).

Now we will look more closely at each component of the system.

Input and output devices

These devices (usually called I/O devices) put data in and receive it back from the CPU.

The CPU does not understand English but follows instructions in a series of binary numbers called machine language. The data it works on is also in binary form. The I/O devices encode the characters in your programs and data into binary numbers when they are used for input, and decode the numbers back into characters when they are used for output.

When a disk drive or a cassette recorder is transferring data to the CPU it is reading the data. When it is transferring it out of the CPU, it is writing the data.

The Keyboard

This is an input device. It is laid out like a typewriter keyboard and you type in your data (and instructions if you are writing a program) as you would type a memo to a member of your staff.

The System-80 Mark II Business Computer also has a numeric keypad. This is to provide you with extra ease and efficiency when entering numbers. It operates in the same way as the number keys on the top of your main keyboard.

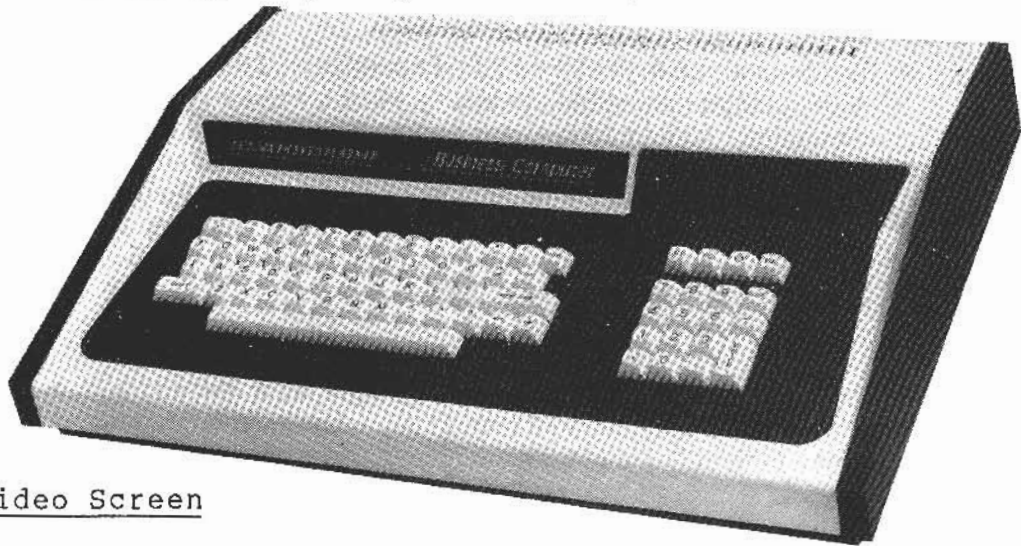

The Video Screen

This is an output device and is like a television set. You can tell the computer to display the results of its work on the screen and it will help you input data or programs on the keyboard by showing the characters as you type them in.

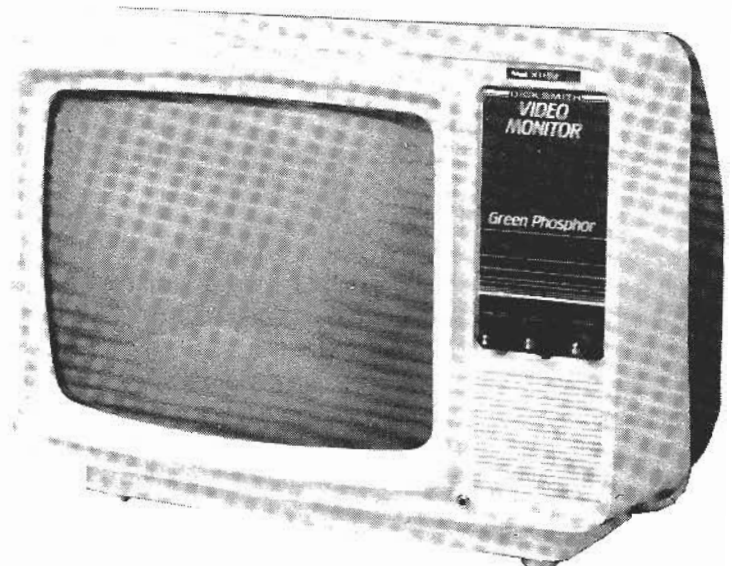

A video monitor. This is our X-1198 monitor, which has a 30-cm green-phosphor screen. The soft green display makes it easier on the eyes, and ideal for extended use.

Printers

These are the output devices that print out the results of the computer's work on paper. A printout of a file is called a hard copy of that file. There are 2 main types of printers:-

- a dot matrix printer uses a series of dots to create the characters you see on the page. It is fast but generally has limited print quality.

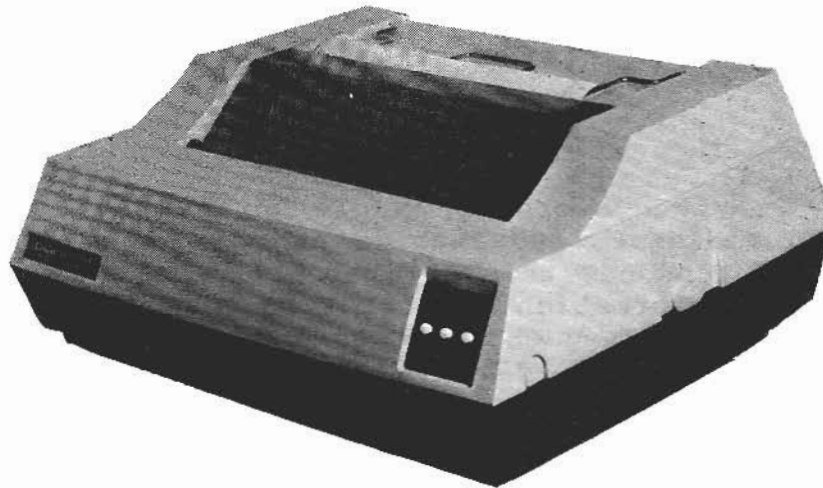

- a daisy wheel printer uses a variety of interchangeable daisy wheels (which work like the golf balls in an electric typewriter) to type the characters on the page. A daisy wheel printer is often slower than the dot matrix printer but produces a much more attractive result and is recommended for word processing work.

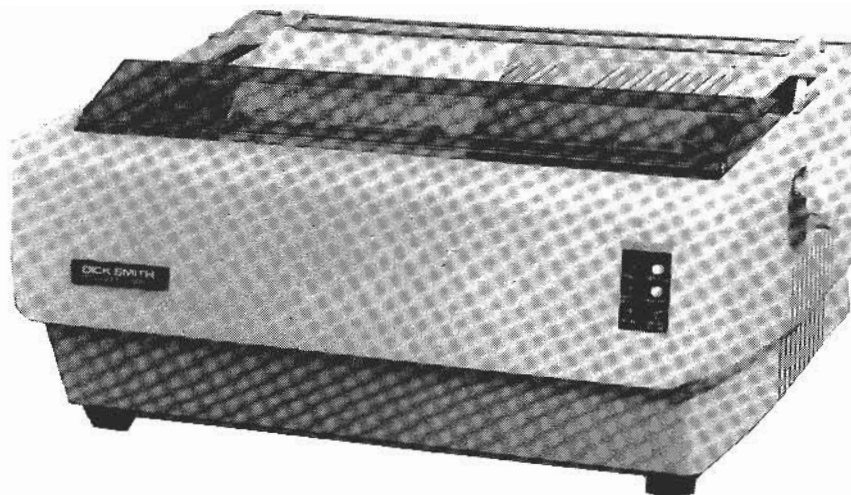

The cassette recorder and disk drives

A floppy disk drive.
This is our X-4050
drive, which provides 40
tracks of storage on a
133mm disk and is
capable of both single
and double density
operation.

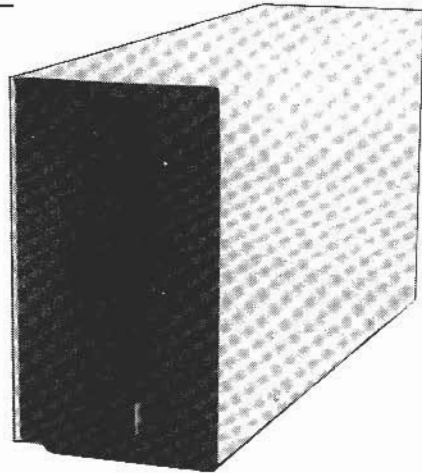

Information is often stored on a disk or tape in blocks which may be given addresses (so that it can be found when you want it). The computer does this automatically. All you have to do is ask for the information according to your file name and the machine looks up its segment address and retrieves it for you.

Data is stored magnetically on tapes and disks. The disk drive and tape drive work as follows -

a) disk drive -

This works a little like a record player. The read-write head moves across the disk tracks and picks up or stores information there. There is, however, a basic difference between a disk drive and a record player. The tracks on a disk are concentric circles, each one separate from the others. They don't spiral towards the centre like the groove on a record. Each track is divided into 10 sectors so that the computer can find the data required by locating the track and sector numbers of its storage place.

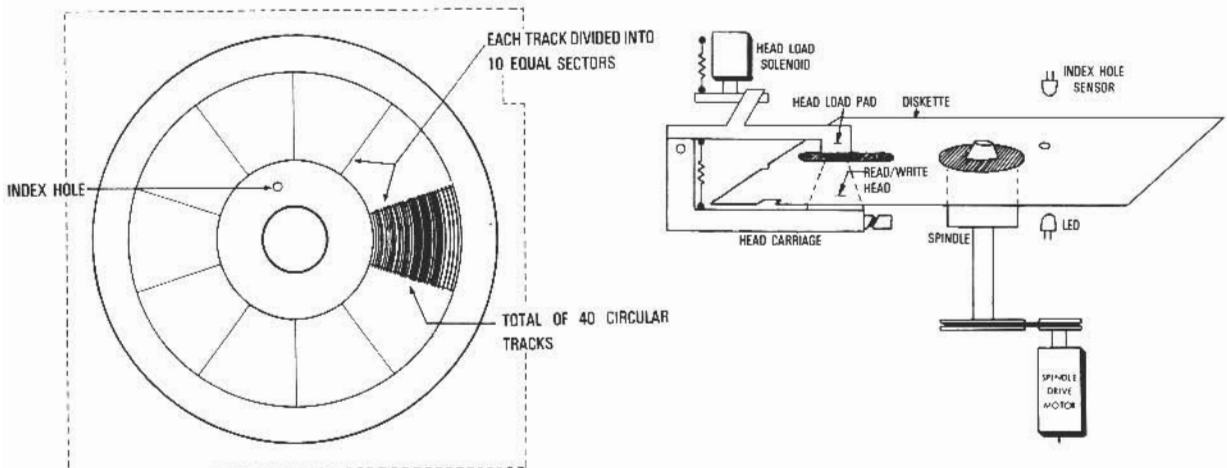



*Write
protect
notch*



NOTE: You can overwrite information on a disk, just as you can record over a tape recording. If you have a disk with data that you want to keep - that is, you do not want to accidentally overwrite it - cover the sensing notch with a write protect tab. Doing this performs the same function as breaking the tab on the back of a cassette. The write protect tab is a piece of opaque plastic or metallic tape that covers the sensing notch and stops the computer from entering or writing information on to the disk.

b) The cassette player

You can use an ordinary cassette player as a tape drive, storing your information on cassettes. The tape drive is less expensive than a disk drive but is slower because of the mechanics involved in its operation. The computer can't rewind the tape and it takes longer to move it forward until the right segment is at the recording head than it does to move a read-write head to the right segment on a disk. Disk drives are recommended for serious business use.

Prevent the computer from writing over important data on a cassette by breaking the tab on the back. This stops over-recording just as it does on a cassette containing music.

A cassette player. This is our A-4095 player, which is very suitable for computer use.



The CPU

The CPU, as mentioned before is that part of the computer which performs calculations and 'organises' the other components of the computer.

It organises the other parts of the computer by using an "operating system". This is a machine language program which stays permanently in the memory of the computer and which tells it what to do in order to manage the other components of the system. There are sets of instructions to actually pass data from the input devices to the CPU and to pass them out again to the output devices. There are sets of instructions to find information on tapes or disk sectors. There are also detailed instructions to the CPU to respond in a particular way to each key on the keyboard. The "DOS" is part of the operating system.

DOS stands for Disk Operating System and is the collection of routine instructions that manage storage and retrieval of information from disks. These routines look after allocating addresses to files (specifying the track and sector in which they are stored), passing information to and from the disk, listing the disk directory for you and so on. Unlike the rest of the operating system, the DOS resides in RAM memory (see later) and typically uses about 7K.

Memory

The computer has a fixed memory capacity. This is measured in BYTES and KILOBYTES. A "48K" memory, for example, is one capable of storing up to 48 kilobytes of data and/or programs.

A byte is roughly the equivalent of a character. That is a letter, number, symbol (eg ~ * \$.) or even the space between the words that you input using the keyboard. A kilobyte (K) is roughly a thousand bytes. A 48K memory, then, can hold up to 48,000 characters.

If you have a computer with 48K of memory, however, that doesn't mean you can only use it to store a maximum of 48,000 characters. The 48K refers to inbuilt memory, or that contained within the computer. You can tell the computer to create external storage areas by outputting data on to disks or tapes thus leaving extra space in the inbuilt memory. It can then retrieve this data whenever it is needed. This effectively increases the size of the internal memory many times over.

Some of the computer's memory is used to store instructions permanently in ROM (or Read Only Memory). This is the type of storage used for the operating system. The operating system is installed in the computer before you buy it. It does not have to be entered. The data and programs that you do enter, however, are not kept there permanently. They can be transferred or outputted to files on disks or tapes and are stored in temporary memory or RAM (Random Access Memory).

The data you enter is usually kept in temporary compartments of the memory called buffers. These are used as way stations for the data, keeping it until you decide where to store it.

A Word About Programs

A program or set of instructions for the computer is designed by a programmer to do a particular task. It is very detailed and often contains thousands of instructions even though it may come to you on a single disk that you buy in one of our stores. This is for various reasons -

- The computer is a 'high speed moron' in the sense that it does not know anything unless you inform it and it will not do anything unless you tell it what to do and exactly how to do it. It has no initiative at all. The programmer, therefore, must work out every possible event that may occur during the execution of the program and tell the computer precisely what to do if that happens.

- This can involve a large number of alternative actions for each step in the program, a large number of alternatives for each alternative and so on. It is very easy to leave something out or even to put an instruction in the wrong place in the list. To avoid such catastrophes the computer programmer uses a planning aid called a flowchart. Below is a sample flowchart covering just the major steps in going through a customer list and sending a reminder letter to all customers who owe more than \$100.

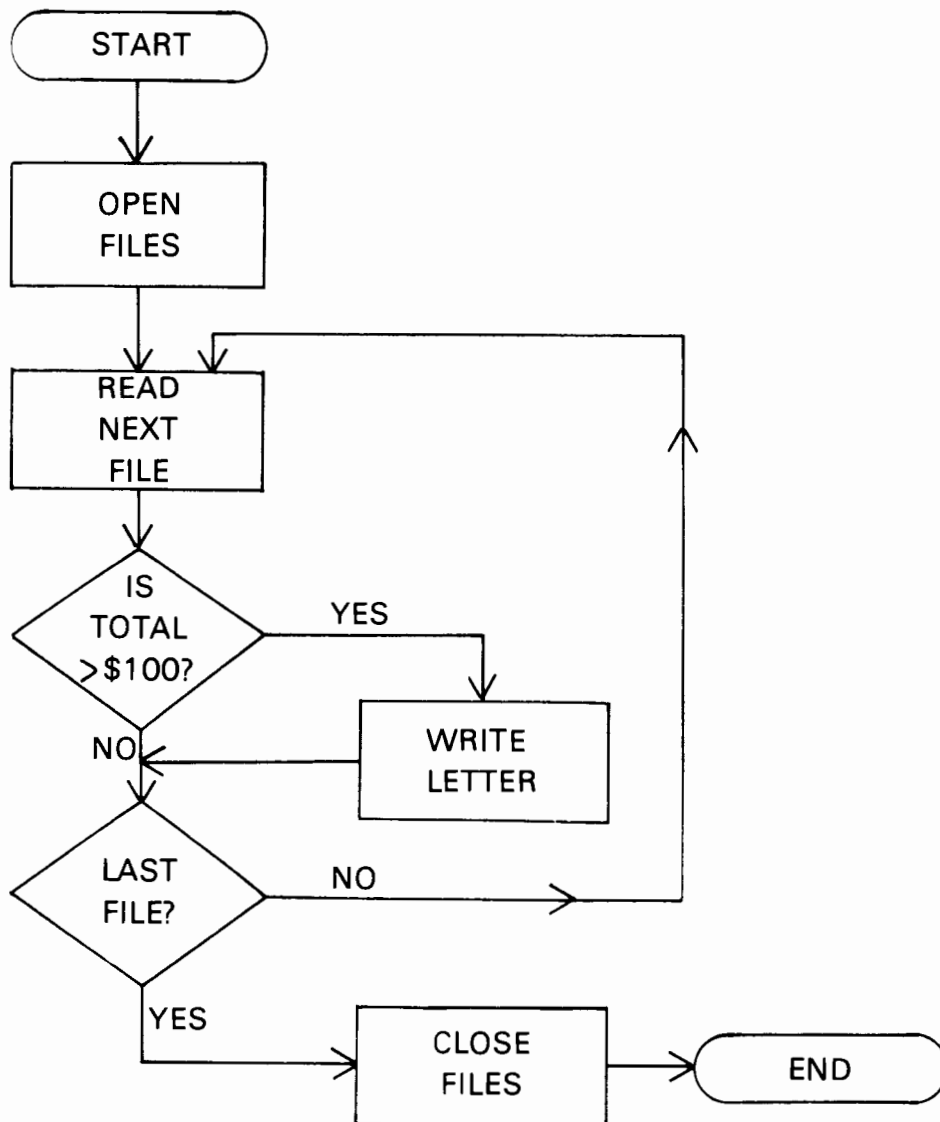

Note that the chart goes through a loop. That is, when a customer is dealt with (the computer has looked at the file and decided whether or not to send the letter), the computer returns to the next customer and repeats the process. Different types of functions are depicted in differently shaped symbols (such as the diamond shape for any "decision making" instruction which could yield 2 or more possible results and the rectangle for any operation involving the use of an I/O device). These make it easier to find a given instruction.

Each one of the steps shown above involves a detailed series of further instructions. For example, the activity of opening the files involves ascertaining where the file is kept (in central memory or on a disk or tape) and writing a detailed procedure for each of these storage devices. If it is on a disk, for example, you must locate the drive it is on, tell the computer what to do if the drive is not connected properly, the disk is damaged, or the wrong disk is in the drive, locate the track and sector addresses for the file, place the read-write head in the correct place, switch to 'read' mode and so on.

A program must be rigorously tested and all possible events simulated before it is ready for use. Mistakes in a program are called "bugs" and the process of correcting those mistakes is debugging. The more complex the program, the more complex and difficult this can become.

Programming languages

The computer, as mentioned before, responds to instructions in machine language which consist of binary numbers. This language is very tedious and difficult for human beings to use so most modern computers have as part of the operating system an inbuilt interpreter or compiler program. These are designed to let a programmer enter instructions in a human-type language. They will translate from these instructions to machine language.

Because English is not a very precise language, programmers enter their instructions in one of a variety of programming languages. There are 2 broad types of programming languages:-

- high level languages are those which are most like English. BASIC, for example (which is the language used to program the System-80 Mark II Business Computer) is a high level language. Other high level languages are COBOL, FORTRAN and PL/1. Languages like these are easier for the programmer to use. Sometimes, however, they are not close enough to the machine language to allow detailed or complicated instructions to be entered.

- low level languages are much closer to the machine language. They are harder to use but give more flexibility when writing complex programs. Assembly language is a low level language.

Systems and system design

A system is a set of programs which all help the computer to carry out a complicated function. A debtors system, for example is a series of programs. One tells the computer how to keep a name and address file for customers, another tells it how to print out statements for customers, another keeps track of the transactions carried out each month and so on. Designing a system involves several steps -

1. The first stage in system design is the initial ideas stage. Here, you identify the problem that you want the computer to be able to solve.
2. The second stage involves assessing the size and scope of the system needed to solve the problem. In this stage, you set the objectives that you want the computer to meet.
3. In the third stage you work out precisely what the system must do in order to meet the objectives. This is called the analysis phase and involves the programmer drawing up functional specifications and getting them approved.
4. The design phase involves planning the system in detail.
5. The construction phase involves translating and programming the system into the computer, testing and debugging it.

The finished system, when it is finally tested and approved is copied onto disks or tapes and instruction manuals are written. The end result of all this effort is a set of completed programs which are simple and easy to use. When you buy a good program, you will never see the complexity of effort and design that has gone into its production.

GLOSSARY OF TERMS

ALPHANUMERIC CHARACTERS - Those characters on the keyboard which are either letters or numbers.

BACKUP - The process by which you obtain a spare copy of the disk or tape you are using. This is a necessary, daily procedure, as disks and tapes are fragile and damaging one could destroy a great deal of information.

BASIC - A language used for entering programs into the computer. The letters stand for Beginners' All Purpose Symbolic Instruction Code.

BAUD RATE - The speed of transmission of data from a serial port along a serial communications line. It is measured in "baud", roughly the same as bits per second.

BINARY CODE - The mathematical code used by the computer for receiving, transmitting, manipulating and storing all data and programs.

BIT - The smallest piece of data that can be stored or sent.

BOOTING or BOOTSTRAPPING - The act of loading the first program into a computer after turning it on. Modern computers, like the Dick Smith computers, have a facility which automatically boots in the DOS.

BROWNOUT - A drop in the voltage supply going to the computer through the mains.

BYTE - The amount of memory needed to store a single character of data. One byte consists of eight bits.

CARD - A printed circuit board which can be inserted or plugged into the expansion unit of your computer.

CHARACTER - Each item entered into the stored text or data using the keyboard. A character can be alphanumeric, a punctuation mark, symbol (# & ` * \$ etc) or even the space between words.

CHIP - A chip of silicon with an integrated circuit on it.

COMMAND - An instruction you give to the computer when you are running a program. The instruction to print a file, for example, is a command.

CONFIGURATION - The arrangement and electrical link-up of the hardware that comprises the computer system.

CONTROLLER - A dedicated or specialised "slave" computer that takes over the detailed housekeeping for the disk drives in response to broad commands from the disk operating system (DOS) in the main computer.

CURSOR - The small flashing rectangular light that appears on the screen to indicate where the next character you enter via the keyboard will appear.

DAISY CHAIN CABLE - A cable which links a series of identical units. In this case the daisy chain cable is used to link the disk drives to the expansion unit.

DAISY WHEEL or PRINT WHEEL - This is a device inside a printer which operates to print out characters in the same way as the golf ball on a typewriter.

DATA - The information you enter into a computer. This data is "saved" or filed on disks, used as the basis for calculations, or formatted and printed.

DATA DISK - If you are using 2 disk drives for running a program on your computer, one of the disks is normally used for storing the program and it is called the "SYSTEM DISK". This disk generally has no new material written on it. The other disk is normally used to store the data you are going to enter (be it records of daily transactions or additions to your inventory list). This is called the "DATA DISK".

DEDICATED COMPUTER - A small processor (generally a silicon chip nowadays) designed to run on one program and carry out a particular function. If you liken the ordinary computer to a pianola, capable of using many different rolls (or programs), the dedicated computer is more like a music box - playing only one tune.

DELETE - The function that erases material from memory or a disk.

DIP SWITCHES - A tiny bank of switches that plugs into a circuit board like an integrated circuit or "chip".

DIRECTORY - A list of the files on a given disk.

DISK - This is a circular disk, similar to a 45rpm record. Information is recorded on its surface magnetically and it is used for storing data or programs for your computer. The disks for the System-80 Mark II Business Computer are 5-1/4" in diameter and are called mini floppy disks.

DISK DRIVE - This is the machine used for recording (or "WRITING") data or programs on to a disk and replaying (or "READING") the information back again.

DOS or DISK OPERATING SYSTEM - The control program which exists on the system disk, is loaded into main memory and subsequently allows the main computer to instruct the disk controller when disk functions are required.

HARDWARE - The machinery or equipment used to make up the computer.

INTERFACE - See PORT.

MEMORY - The part of a computer's hardware which is used to store data and programs.

MODE - an aspect or kind of operation. EDIT mode, when used in word processing, for example, is that aspect of operation that allows you to change text in a file.

MODEM - A piece of equipment for sending binary codes over telephone lines, thus allowing computers to send and receive information on the telephone. The name stands for MODulator/DEMulator. The modulator translates the binary code into whistles which can be transmitted over the phone and the demodulator translates the whistles back into binary code.

OPERATING SYSTEM - A series of programs fixed in the computer which instruct it on how to carry out its day to day operations. For example, the procedure for transferring data from memory to the printer is programmed into the operating system.

OVERWRITE - The act of recording over (and therefore replacing) information on a disk or tape.

PERIPHERALS - Those pieces of equipment that are "attachments" to the main unit or expansion unit of the computer. Printers and disk drives are peripherals.

PORT or INTERFACE - This is the socket and circuitry allowing the connection of a peripheral to the CPU or expansion unit. Ports can be parallel or serial depending on the way the electric impulses carrying data and programs are transported along the cable to the port.

PROGRAMS - The sets of instructions that tell the computer what to do in order to perform the function you require of it.

RAM or RANDOM ACCESS MEMORY - Temporary memory that is accessible to the user for storing data or programs.

READ - The computer's act of "playing back" data or programs contained in memory or on disks or tapes.

RIBBON CABLE - A type of multi-wire cable named for its ribbon-like shape. The wires are embedded side by side in a plastic sheath.

ROM or READ ONLY MEMORY - Permanent memory in the computer, used for housing programs like the operating system.

"SLAVE" COMPUTER - A dedicated computer which is part of a larger system and is controlled by a general purpose computer.

SPIKE - A surge of extra voltage to the computer through the electrical mains.

STRING - A set of characters in a particular, significant order. A word, for example, is a string.

WRITE - The computer's act of recording data or programs in memory or on to a disk or tape.

WRITE PROTECT NOTCH or SENSING NOTCH - A small notch on a disk which, when covered with a "WRITE PROTECT TAB", will prevent the computer from recording or writing over data already on the disk.

DICK SMITH ELECTRONICS

SHOP 4, 399 LONSDALE ST.,

MELBOURNE VIC. 3000

PHONE No. 67-9834

DICK SMITH Electronics

bonhcard
welcome here



HEAD OFFICE AND MAIL ORDER CENTRE: PO Box 321, NORTH RYDE, NSW 2113. TEL (02) 888 3200. TELEX AA20036 CABLES 'DIKSMIT, SYDNEY'

INCORPORATED IN NSW

NSW Parramatta Rd & Melton St	AUBURN 648 0658	NSW George & Smith Sts	PARRAMATTA 689 2188	VIC 399 Lonsdale St	MELBOURNE 67 9834	WA William St & Robinson Ave	PERTH 328 6944
155 Terrace Level	BANKST. SQ 707 4889	6 Bridge Street	SYDNEY 27 6051	Bridge Rd & The Boulevarde	RICHMOND 428 1614	Canterbury Ave., Hay St	PERTH Open Soon
613 Princes Hwy	BLAKEHURST 546 7744	125 York Street	SYDNEY 290 3377	Springvale & Dandenong Rds	SPRINGVALE 547 0522	25 Barrack Street	HOBART 31 0800
Oxford & Adelaide Sts	BONDI JCT 387 1444	Tamworth Arc & Kabie Ave	TAMWORTH 66 1961	293 Adelaide Street	BRISBANE 229 9377	Also in Auckland, New Zealand. Re-sellers across Aust & NZ.	
818 George Street	BROADWAY 211 3777	173 Maitland Rd	TIGHE HILL 61 1896	186 Logan Road	BURANDA 391 6233	Check with local store for store hours.	
531 Pitwater Road	BROOKVALE 93 0441	263 Keira Street	WOLLONGONG 28 3800	Gympie & Hamilton Rds	CHERRMSIDE 59 6255	Any terms offered are to approved, personal applicants	
147 Home Hwy	CHULLORA 642 8922	96 Gladstone Street	FYSHWICK 80 4944	Wright & Market Sts	ADELAIDE 212 1952	through HFC finance. Terms not available by Mail Order.	
162 Pacific Hwy	EGRE HILL 439 5311	280 Sydney Road	COBURG 383 4455	Main South & Flagstaff Rds	DARLINGTON 298 8977		
Elizabeth Dr & Bathurst St	LIVERPOOL 600 9888	Napean Hwy & Ross Smith Ave	FRANKSTON 783 9144	Main North Rd & Darlington St	ENFIELD 260 6048		
Lane Cove & Waterloo Rds	NORTH RYDE 888 3200	205 Melbourne Road	GEE LONG 78 8766	WA Wharf St & Albany Hwy	CANNINGTON 451 8686		